



AutoCAD[®]

MEP 2008

A better, faster AutoCAD for MEP
engineering design and documentation.

Autodesk[®]

Increase Efficiency with Improved Drafting Productivity

Discipline-Specific Tool Palettes

Provide all team members with the right tools for the job. A discipline-specific engineering tool palette displays only the tools relevant for the mechanical, electrical, or plumbing engineering user, providing consistency across project drawings. Organize the tool palette to specific company or individual preferences. Now engineers, designers, and drafters can easily modify tool palette size, shape, system type, and much more using in-place editing. Simply select the tools you want to change, and modify the common properties at once, streamlining the design process and improving productivity.

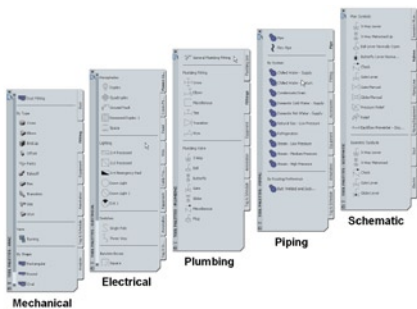

Properties Palette

The Properties palette enables engineers, designers, and drafters to specify just the things that are important to them about the equipment parts they're adding. The equipment part name and size are easy to access at the top of the Properties palette. Add/modify equipment and devices in one location through the Properties palette.

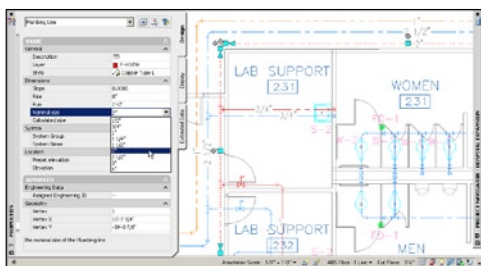

Project Navigator—Drawing Management

Easily manage project drawings, create coordinated views based on designs, and manage drawing sheet sets. Since the drawings are managed from a centralized project directory, everyone on the design team can consistently access the most current documents, from project templates to sections and elevations. New project standards make it easier to share project information.

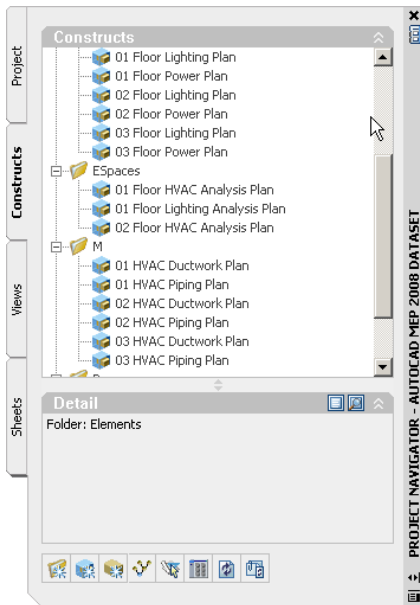

Dynamic Dimensions

As engineers, designers, and drafters make changes to their mechanical, electrical, or plumbing design, they benefit from the Dynamic Dimensions feature, which gives real-time feedback on the exact location of a move or copy change within their design. This capability facilitates Heads-up Design™ functionality, speeding the production process for faster delivery of construction documents.

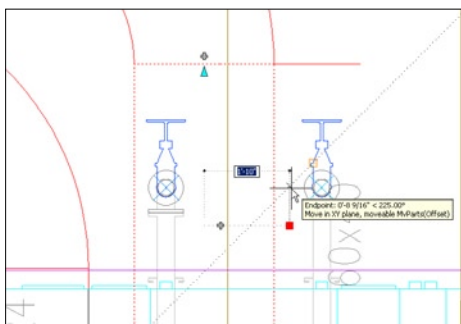

Edit-in-View

AutoCAD MEP streamlines design productivity by providing multiple views from which the user can modify the MEP systems design. Easily work in a specific area of the design in any view desired and not be constrained by working only in plan view.

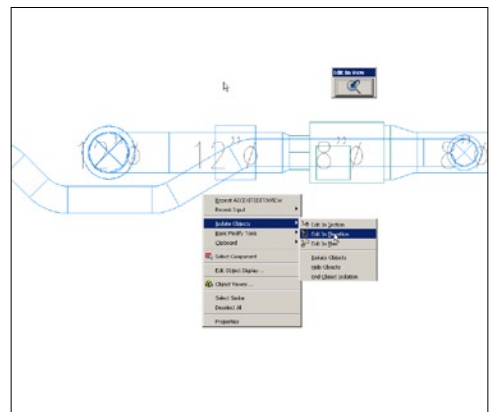

Single-Line Duct Design

Easily move from design development to construction documents. Lay out mechanical systems in a single line with unsized parts, and then quickly convert the layout to a double-line representation of the system. Benefit from connectivity enhancements to automatically connect unsized sections of the design layout to sized sections.

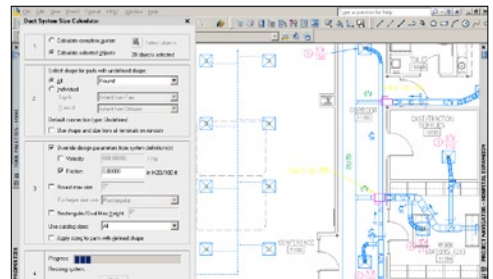

Make a Seamless Transition from Traditional Drafting Processes

AutoCAD MEP enables engineers, designers, and drafters to move from design to documentation faster through the automated production of construction documents with discipline-specific, AutoCAD-based tools.

Increase the efficiency of design development and construction documentation processes using actual industry-based content. Reuse design data by linking to industry-leading analysis, cost estimation, and fabrication software applications.

Templates

Easily create and maintain all company standards in one location for updating. The templates hold all layers, system definitions, styles, drawing setup and plotting preferences, and much more. Use the template to start all drawings and projects for companywide consistency. Layer standards and system definition capabilities have been enhanced.

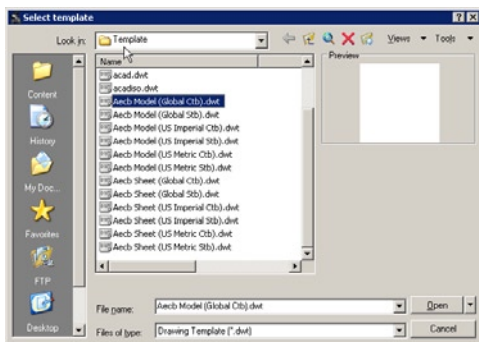

Convert AutoCAD Blocks and Symbols to AutoCAD MEP Content

Easily migrate your existing AutoCAD symbols to AutoCAD MEP content for production of construction documentation. Existing AutoCAD blocks and symbols are easily converted to AutoCAD MEP content, in one easy step, using the new symbol and device converter.

Interference Detection

Automatically detect spatial interferences between engineering systems, structural elements, and architectural content, in the same drawing or through xrefs. Use this powerful feature to increase design accuracy and minimize errors in the field.

AutoCAD and AutoCAD Architecture Support

Import architectural floor base plans developed in any AutoCAD-based software application to facilitate better design and documentation coordination. Since AutoCAD MEP is built on AutoCAD and AutoCAD Architecture software, coordination among team members and design teams has never been easier within the complex building design process.



Systems

Provide a fast and consistent method for laying out parts that represent real-world building systems, such as air supply or return systems. When designers use systems during design layout, new parts inherit the current system's defaults, such as rise/drop symbology and display properties, and designers can apply changes simultaneously to all connected parts. And since AutoCAD MEP manages layers, systems can be assigned to layers, helping ensure the accuracy of designs.

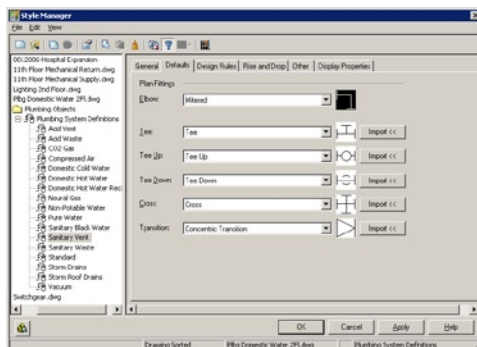

Standards-Based Parts

AutoCAD MEP provides an extensive collection of parts, fittings, and equipment based on widely adopted industry standards, helping to ensure consistency and accuracy in your designs. New content includes additional fittings and equipment, as well as support for ASME/ANSI and ASTM/ANSI standards. AutoCAD MEP supports metric units in addition to imperial units. Metric content is located in a separate catalog. Metric content is based on GSA (General Services Administration) U.S. guidelines and BSI (British Standards Institution) U.K. guidelines.

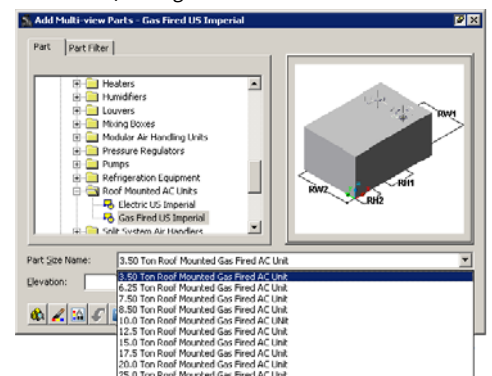

AutoCAD MEP design and documentation capabilities will definitively have a positive impact on our repeat business. It really helped the owner and building operator visualize exactly what we were doing—even in the middle of a very large mechanical room with a number of existing services.

—Doug Reinbold, PE
Principal
Reinbold Engineering Group

Export to AutoCAD

Export to AutoCAD enables designers to easily generate AutoCAD DWG™ files to distribute to consultants who may be using various versions of AutoCAD. The export capability maintains complete graphic representation of symbols and devices as shown on construction documentation. What you see in AutoCAD MEP is what you get when exporting to basic AutoCAD.

Built on AutoCAD

Because AutoCAD MEP includes the latest version of AutoCAD software, users get all the added benefit of the features and functionality in AutoCAD. And since AutoCAD MEP is built on AutoCAD, it supports existing AutoCAD-based custom LISP routines.

Work with Enhanced AutoCAD Commands

Copy, move, and align all in one step with enhanced AutoCAD commands unique to AutoCAD MEP. Automatically snap in the required orientation and view. Quickly array along duct, pipe, conduit, or cable trays and easily fillet plumbing piping.

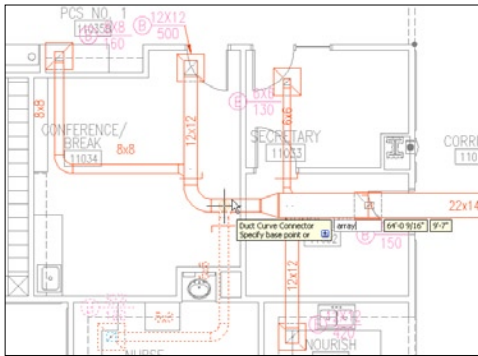

AutoCAD MEP has created the next jump in productivity. It's definitely faster for creating drawings, minimizing mistakes, and saving on drawing time. With AutoCAD MEP, we estimate our engineers are creating construction documents 50 percent faster and modifying those 70 percent quicker.

—Reg Monteyne
Senior Vice President
Flack+Kurtz

Connect to Industry-Leading Cost Estimation, Fabrication, and Analysis Applications

Reduce time-consuming input of existing design information. Extract engineering data created in AutoCAD MEP using the industry-leading DWG file format or through the application programming interface (API) for use with third-party cost estimation, fabrication, and analysis applications. For a complete list of partner solutions, go to www.autodesk.com/partnerproducts.

Custom Content Tools

Create custom parts and equipment with minimal effort and time. Use the enhanced Content Builder to create AutoCAD block-based parts that can be used in your MEP systems design. Use existing standard shapes such as box, cylinder, or sphere, as well as freeform modeling tools to create your custom parts.

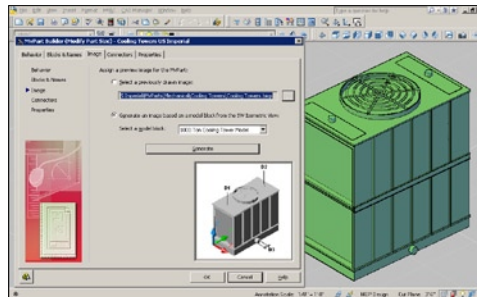

AutoCAD MEP is really helping TLC take all the various pieces that go into a building and visualize them, make sure they fit, and make sure they are routed in the most direct and convenient way. Having the intelligence embedded into the electronic data for the building enables us to provide our clients with a database of information that they can use to manage the building throughout its lifecycle.

—Winston W. (Bud) Gardner, PE
President and COO
TLC Engineering for Architects

Setup and Deployment Options

Flexible setup and deployment options provide for consistent standardization and management of software installations for both network and single-user installations. And through the use of profile-based shortcuts, the software can now automatically default to specified template drawings when opened.

AutoCAD Revit MEP Suite

AutoCAD MEP software is available as either a stand-alone software application or as part of AutoCAD® Revit® MEP Suite, which also includes Autodesk's leading building information modeling software application for MEP engineering, Revit® MEP software. For more information, visit www.autodesk.com/revitmepsuite.

Produce Accurate Construction Documentation in Less Time

Minimize documentation coordination errors between mechanical, electrical, and plumbing engineering design teams as well as with architects and structural engineers within an AutoCAD-based workflow.

AutoCAD MEP helps reduce requests for information (RFIs) and costly design changes in the field by enabling more accurate and consistent construction documents. Collaborate seamlessly when you take advantage of the architectural base plans developed using AutoCAD-based software applications. Autodesk's industry-leading DWG file format lets you easily share your work with your entire team.

Single Line and Double Line

AutoCAD MEP facilitates routing of ductwork, piping, cable tray, and conduit with intuitive design tools that automate much of the layout process. Increase productivity with automated routing solutions based on default project settings and common industry design standards. With improved connectivity between objects, automated system layout is even easier. Improved layout tools make it easier to convert one-line designs to double line through intuitive onscreen modification.

Custom fittings enable unique layouts to be designed with the creation of on-the-fly fittings. And options such as segment length help reduce time spent performing takeoffs by graphically depicting each segment piece that is required for the layout according to manufacturers' specifications.

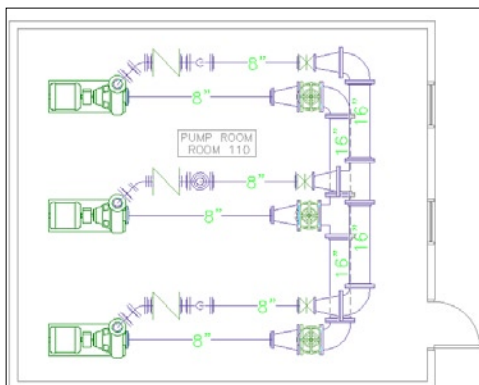

Sections and Elevations

Create sections and elevations quickly in seconds rather than hours. When designers make a change in the design, sections and elevations update automatically, saving time and helping ensure accuracy in the design. Each design change is reflected in real time, minimizing tedious manual updates.

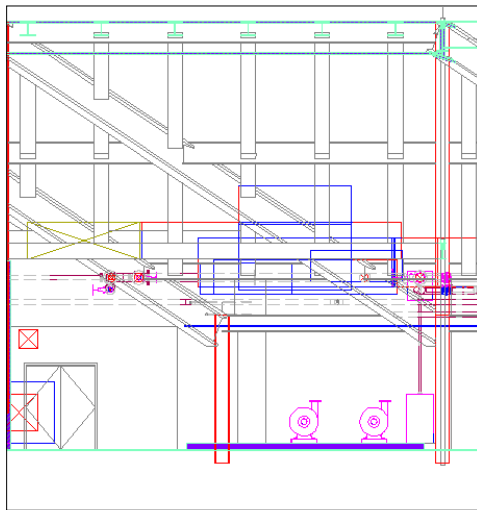

After implementing AutoCAD MEP, HCE has seen a 50 percent jump in productivity. It's giving our engineers the ability to reduce their drafting time and improve accuracy. Because of this, we're saving time on project revisions and getting accurate construction documents completed on time.

—Tom Harris, PE
President and Principal
Electrical Engineer
Harris Consulting Engineers, LLC

Scheduling

Create schedules in seconds, saving hours over traditional CAD drawing processes. Schedules are automatically updated as the design changes, helping to reduce errors in construction documents. Now engineers, designers, and drafters can schedule engineering system data, calculate values, and use new table styles to lay out room and analysis schedules.

Construction Annotation

Simplify the process of annotating construction documents with automated annotation tools. AEC dimensions and dynamic labels update automatically as the design changes, eliminating many manual updates. Hidden lines and hatch-on objects make it easy to interpret design intent. In this release, new ease-of-use tools and enhanced grips streamline the use of break marks, labels, and scheduling tags. Display the schematic view of an object rather than the model-generated view. Create schematic block, annotation, or both that scale when the part size changes.

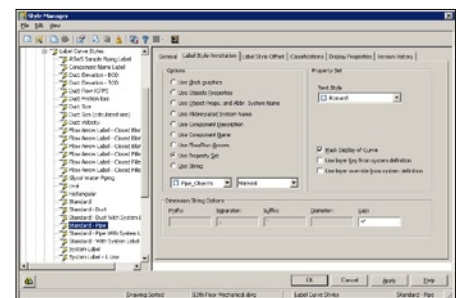

Display Manager

Easily change the level of detail for design views with preset display options. Since each view is based on the design, any change is automatically reflected throughout all views of the design data. This release introduces support for multiple drawings and enables drag-and-drop editing of display information. It also provides project standards support for sharing displays.

Circuit Manager

Work more efficiently using a single location to manage and edit circuit information. Automatic prompts notify users of potential overloads and undersized wires based on conductor size, helping avoid errors and rework.

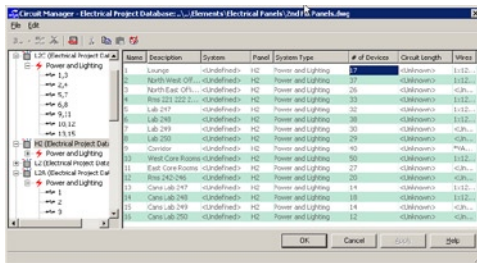

Spaces and Zones

Assign engineering spaces from existing 2D architectural floor plans or design drawings, and AutoCAD MEP automatically calculates room measurements, including square footage/square meters and volumes per room or area. Easily allocate room usage to your engineering spaces in your project, for example “Office Area,” “Conference Space,” “Hallway.” Used with industry-leading analysis applications, AutoCAD MEP enables you to automatically calculate load capacity and airflow rate requirements per room type or areas.

Isometric and Plan Schematics

Quickly produce schematics and riser diagrams without the hassles of trimming lines and rotating blocks. Use a customizable collection of 2D schematic lines and symbols and automated tools for easy creation and modification.

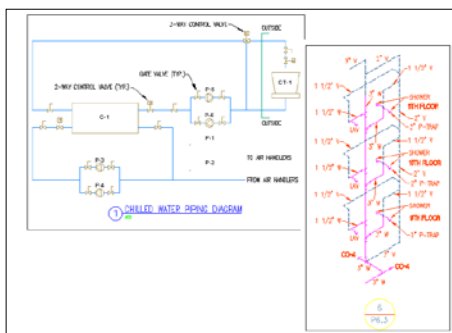

Publishing Tools

With the click of a button, publish designs, drawings, and part catalogs to share with other members of the extended design team. Save your AutoCAD MEP design in Autodesk® Design Review, and allow for easy viewing of the project by members of the design team, while protecting the original data from change. AutoCAD MEP supports the creation of 3D DWF™ files, complete with engineering data, for better communication of design intent.

eTransmit

Share sheets, sheet sets, or complete projects with the extended design team quickly and easily with eTransmit, enabling all associated drawings files and xref files to be included. Take advantage of the option of saving designs as AutoCAD DWG files in one easy step when coordinating with members of the design team using various versions of AutoCAD software.

Engineering Display Themes

Use display themes to graphically present and analyze design intent. For example, use the display theme By Velocity or Friction Loss to validate system performance for a particular area or room. Also use the display theme By Pressure Class to visually show the high, medium, and low-pressure per piping class to easily identify potential design flaws. Display themes are depicted as color-filled displays complete with legends.

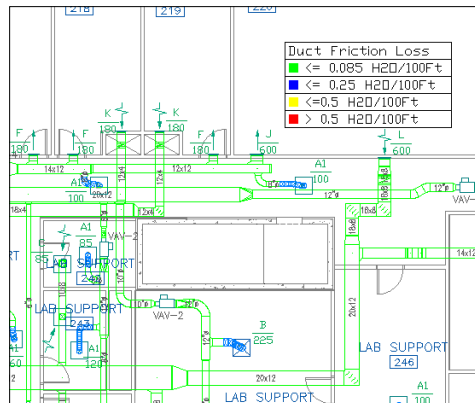

Autodesk building solutions help us provide a more comprehensive, integrated solution to our clients and meet our long-term strategic goals.

—Mark Butler
Senior Systems Analyst
HDR

Electrical Devices and Panels

Quickly and easily lay out the basic circuitry for a project by placing devices on defined circuits and associating the circuits with a panel, creating logical relationships in electrical designs. Take advantage of the ability to automatically generate wiring to increase production.

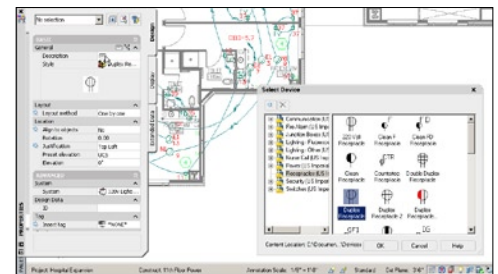

Import/Export to gbXML (Green Building)

Import to and from AutoCAD MEP using the industry-standard green building extensible markup language (gbXML) file format. This capability enables engineers to query the compliance of engineering systems in their design to green building standards.

Import LandXML

Import LandXML data from a civil application, such as AutoCAD® Land Desktop, to add an accurate digital terrain to a drawing in order to accurately understand the details of the building site without having to redraw it.

Autodesk VIZ Render

With Autodesk® 3ds Max® technology at its core, Autodesk® VIZ Render, a streamlined and simplified visualization application that is fully integrated into the AutoCAD MEP workflow, helps designers use the model to produce design presentations suitable for any stage of design development. This release supports 3D DWF export and batch rendering, and provides additional lighting tools.

Get the Most Functionality

Production of Construction Documentation	AutoCAD	AutoCAD MEP
Automated sheet management	•	•
Ability to manage/update project standards	•	•
Direct editing and instant onscreen feedback	•	•
Ability to import/export data in DWG, DWF, and other formats	•	•
Centralized management of project files	•	•
Ability to work in multiple views and schedules		•
Automated display support for multiple display representations		•
Automated schematic and annotation tools		•
Automatic generation of sections and elevations		•
MEP Engineering Tools		
Purpose-built tools for mechanical, electrical, and plumbing design		•
Standards-based part libraries		•
Routing tools for ductwork, piping, cable tray, and conduit		•
Built-in sizing calculators for duct, pipe, and wire		•
Ability to manage electrical circuit design		•
Automated system zoning		•
Automated tools for converting sketches to system designs		•
Support for drawing connectivity through xrefs		•
Automatic generation of 3D model		•
Interference checking tools		•
Creation tools for customized symbols and parts		•
Additional Features		
Supports multiuser/multidiscipline project environment	•	•
Supports collaboration/workflow with professionals using AutoCAD	•	•
Customizable user interface	•	•
Supports rendering, visualizations, and presentation graphics	•	•
Customizable API supports variety of in-house functions	•	•
Wide variety of third-party applications available	•	•

This table compares the features of AutoCAD and AutoCAD MEP software products to help you make the best choice for your business. AutoCAD software is the world's leading customizable and extendable CAD application for 2D drafting and design documentation.

AutoCAD MEP is a purpose-built AutoCAD product specifically developed for mechanical, electrical, and plumbing design and documentation for buildings. AutoCAD MEP enables engineers, designers, and drafters to realize immediate productivity gains within existing AutoCAD-based engineering workflows, by accelerating design and documentation productivity, accuracy, and coordination.

Autodesk Services and Support

Accelerate return on investment and optimize productivity with innovative purchase methods, companion products, consulting services, support, and training from Autodesk and Autodesk authorized partners. Designed to get you up to speed and keep you ahead of the competition, these tools help you make the most of your software purchase—no matter what industry you're in. To learn more, visit www.autodesk.com/servicesandsupport.

Autodesk Subscription

Ensure competitive advantage by keeping your design tools, and your design skills, up to date easily and cost-effectively with Autodesk® Subscription. Get the latest versions of your licensed Autodesk software, incremental product enhancements, personalized web support direct from Autodesk, and self-paced training options with one annual fee. To learn more, visit www.autodesk.com/subscription.

Learn More or Purchase

Access specialists worldwide who can provide product expertise, a deep understanding of your industry, and value that extends beyond your software purchase. To purchase AutoCAD MEP or AutoCAD Revit MEP Suite, contact an Autodesk Premier Solutions Provider or Autodesk Authorized Reseller. To locate the reseller nearest you, visit www.autodesk.com/reseller.

For more information about AutoCAD MEP software, visit www.autodesk.com/autocadmep. To learn more about Autodesk Solutions for mechanical, electrical, and plumbing engineering, visit www.autodesk.com/building.

Cover image courtesy of Total Mechanical, Inc.

Autodesk, AutoCAD, DWF, DWG, Heads-up Design, Revit, and 3ds Max are registered trademarks or trademarks of Autodesk, Inc., in the USA and/or other countries. All other brand names, product names, or trademarks belong to their respective holders. Autodesk reserves the right to alter product offerings and specifications at any time without notice, and is not responsible for typographical or graphical errors that may appear in this document. © 2007 Autodesk, Inc. All rights reserved. 000000000000117725